

▼ XC1502TE



Portable Battery Pump for Torque Applications

- Ideal for maintenance bolting applications requiring portability and convenience
- Interactive pendant provides visual and vibration feedback of pump operation
- Intelligent Auto-Cycle enables press and release actuation to cycle torque wrench until final torque is achieved
- User can set pressure and operate in manual or auto-cycle mode
- Superior run-time with 5Ah, 28V battery
- 6 metres detachable pendant control
- 100 mm glycerine-filled gauge for easy viewing
- Bladder reservoir allows pump to be used in any position
- High-strength fiberglass reinforced composite housing provides superior durability in demanding job site environments
- Integrated handle and carrying strap for portability.



28-Volt Battery

The **XC28V5** 5 Amps battery with Lithium-Ion technology for maximum battery performance.



Roll Cage

Roll cage accessory option for both XC-TW and XC pump. Please order model number **XCRCTK**.



Torque Wrenches

The following torque wrenches are ideal for use with the XC-Series Cordless Torque Wrench Pumps:

S-Series	W-Series	RSL-Series
S1500X	W2000X	RSL1500
S3000X	W4000X	RSL3000
		RSL5000

Larger torque wrenches will work with the pump, battery run time and application speed will be impacted.

XC-Series, Cordless Torque Wrench Pumps



Battery-Powered Torque Wrench Pumps

The XC-Series Cordless Torque Wrench pump is ideal for maintenance applications in the PowerGen, Oil & Gas and MRO markets. This portable pump is perfect for remote locations, sites that do not have access to power or where trip hazards are a concern.

The interactive pendant allows the user to set and clear pressure and operate in manual or auto-cycle mode. The pump has an easily accessible user adjustable valve for precise pressure control.

Torque Wrench	Nut A/F (mm)	Stud (mm)	Pressure (bar)	Torque (Nm)	Fasteners torqued
S3000X	60	38	330	2035	32
W2000X	60	38	350	1356	52

XC Series



Reservoir Capacity:
2,0 litres

Flow at Rated Pressure:
0,25 l/min

Motor Size:
0,37 kW

Maximum Operating Pressure:
700 bar

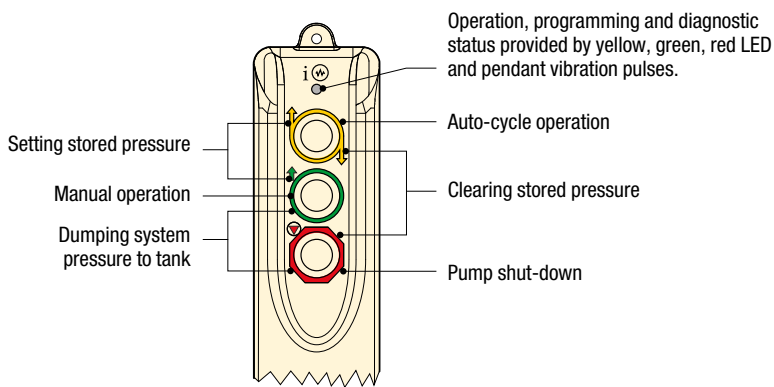

Torque Wrench Hoses

Use Enerpac 700 bar THQ-700 Series torque wrench hoses with torque wrenches and pumps

2 m long, 2 hoses	THQ-702T
6 m long, 2 hoses	THQ-706T
12 m long, 2 hoses	THQ-712T

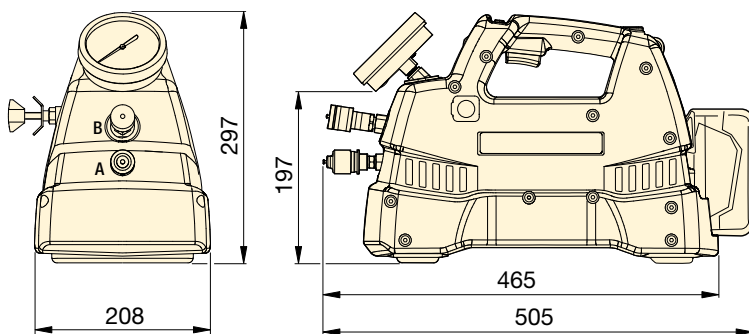

OIL FLOW vs. PRESSURE

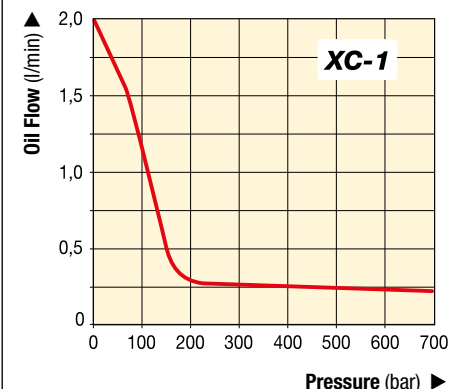

SELECTION CHART

Description	Useable Oil Capacity (litres)	Model Number	Output Flow Rate (l/min)			Included with pump	Weight (kg) ¹⁾
			No Load	140 bar	700 bar		
Cordless Pump Kit	2,0	XC-1502TB	2,05	0,49	0,25	2 batteries and 115V charger	12
Cordless Pump Kit	2,0	XC-1502TE	2,05	0,49	0,25	2 batteries and 230V charger	12
Cordless Pump	2,0	XC-1502T	2,05	0,49	0,25	No batteries or charger	12

¹⁾ Weight includes oil, without battery. battery weight 1,1 kg